

CARTRIDGE DUST COLLECTOR BEHAVIOR OVER A RANGE OF INLET CONDITIONS

by

Gary Berwick, P.Eng.
Quality Air Management Corp.

Cartridge collectors, although similar to reverse jet pulse fabric collectors have some peculiar operating characteristics listed below. These are all related to the shape and construction of the filter element:

- 1) Pressure Drop
- 2) Cleaning System Actuation
- 3) Response to Varying Loads
- 4) Failure Modes

MECHANICS OF STEADY STATE CLEANING

First it would be beneficial to review the steady state operation of a fabric pulse collector with cylindrical bags. (Fabric pulse jet collectors with envelope bags have sufficiently similar characteristics so they will not be considered separately.)

Refer to Figure 1. The conventional designs have orifices and so-called venturiers, which are actually pneumatic ejectors in the mouth of each bag. This combination develops a flow in the ejector, which is three to five times the filter-flow.

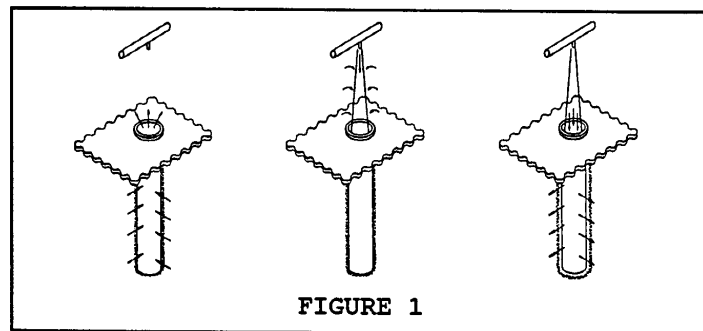

During the cleaning cycle the following mechanism occurs:

- The flow upward from the top of the bags is first stopped.
- The ejector flow continues to increase until the net flow in reverse is sufficient in both volume and pressure to increase the permeability of the filter cake. In the process, dust that agglomerated within the filter cake is propelled from the filter cake into the adjoining space. The agglomerated dust has a much higher conveying velocity than the filter velocity toward the media, so it migrates into the dust collection hopper. In order to develop sufficient velocity pressure to overcome the anticipated pressure drop across the filter element, the net velocity pressure of the cleaning air coming down the bags must be in excess of that pressure drop. As suppliers offered longer and longer bags, the designers increased the reverse airflow without increasing the diameter of the venturi nozzle.

- The net venturi velocity during cleaning for most collector designs is over 20,000 fpm, which corresponds to a velocity pressure of 24" water gauge. The velocity, at which the dust is propelled from the bags, is proportional to this venturi velocity. For reasons beyond the scope of this paper, the actual propulsion velocity is equal to, or higher than the venturi velocity.

The main failure mode of a reverse fabric collector is that during cleaning the dust from a row of bags while cleaning is driven into the adjoining rows of bags that are in the Filtering mode.

Despite the fact that a failed bag usually has a lot of dust on the outside, the high pressure drop and the dust on the outside is due to the fabric filter media being plugged because the dust was driven through the cake and became embedded in the media on the clean side by subsequent cleaning cycles.

The cartridge collector corrects this main failure mode of a reverse jet fabric collector.

Since the reverse cleaning air is always at a higher pressure than the air on the dirty side of the filter media, the air and dust will be propelled away from a filter/cake surface at an angle perpendicular to this surface. Referring to Figure 2A, you will note that in a cylindrical element the dust is propelled into adjoining filter bags, which are under vacuum. The dust at this high velocity is aided by the vacuum to penetrate into the inside of the bag. Once it penetrates, subsequent cleanings drive it into the media, where it stays and progressively blinds the bag.

However, in Figure 2B, you will note that perpendicular to the surface of a pleated cartridge filter, the propelled dust and air strikes another surface cake in which all of the openings are filled with high velocity cleaning air. This eliminates the penetration of dust into the collector during the cleaning cycle.

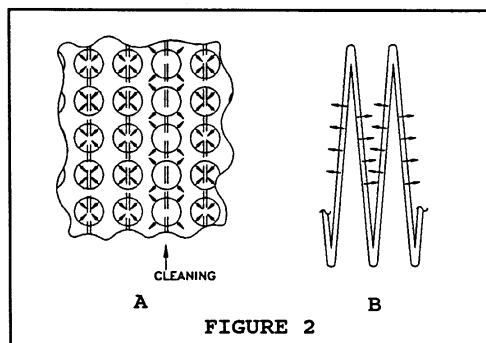

FIGURE 2

CARTRIDGE COLLECTOR CLEANING MECHANICS

Although the basic systems for cleaning cartridge elements are similar, there are some very important differences that relate to the pleated media configuration. For purposes of illustration, consider the process of cake formation.

Area of filter/filter-cake that is cleaned is (in either cylindrical bags or cartridge elements) variable and depends on the following:

- The net volume of cleaning air in the reverse jet.
- The porosity of the filter cake (defined as permeability).
- The amount of unplugged filter media available.

CAKE FORMATION

When the filter element is first installed (either cartridge or fabric, the porosity is usually so high that the jet will continue to grow on the dirty side as if the element were not present. As the cake begins to form the permeability reduces to a point where the resistance across the cake becomes high enough that the jet will stop expanding outside the filter element and the cleaning cycle will begin (Figure 3). When the cake first forms it is very porous. The porosity (permeability) will determine how much of the cake is cleaned. The velocity of cleaning air through the openings will increase as the cake becomes dense and offers more resistance. Increasing the reverse flow volume will clean more of the filter cake area.

If none of the cake is plugged:

- 1) Amount of filter cleaned is directly related to permeability;

$$\begin{aligned} \text{Area Cleaned} &= \text{Permeability} \times \text{Constant} \\ A &= P \times B \end{aligned}$$

Where P is Permeability in cfm/sq.ft. at 0.5 in. w.g., A is area in sq.ft., and B is a constant

- 2) Amount of filter cleaned is also related to the net reverse air flow;

$$\begin{aligned} \text{Area Cleaned} &= \text{Net Reverse Flow} \times \text{Constant} \\ A &= F \times C \end{aligned}$$

Where F is flow in cfm, A is the area of the filter cloth in sq.ft., and C is a constant.

This reduces to an equation;

$$A = P \times F \times K$$

Where K is a combined constant.

The process of cleaning the filter element reduces the porosity of the filter and also the collection efficiency. It is important to reduce cleaning frequency to a point where the filter cake will result in optimum efficiency. This point is where the maximum of cake is cleaned by the reverse air jet.

CARTRIDGE TEST DATA

The range of frequency of cleaning settings is quite wide, but in general we want to clean at the lowest practical pressure drop and at the minimum cleaning frequency. Table 1 indicates some results of tests on a cartridge

collector where the inlet loads were extremely low (less than 1.25 % of anticipated design inlet load) and the cleaning frequency set at cleaning the collector at the design load.

<u>Inlet Load</u>	<u>Collection Efficiency</u>
0.0012 grains/cu.ft.	46%
0.0086 grains/cu.ft.	76%
0.0248 grains/cu.ft.	84%

Table 1

At the proper cleaning frequencies, which were once every four to eight hours, for this range of inlet loads, the collection efficiencies were over 99.5%.

CARTRIDGE TEST INFORMATION

In an effort to quantify cartridge filter performance over a range of inlet conditions, a controlled test was setup. The test equipment consisted of a QAM-400 collector with eight small cartridge elements, a continuous feeder to introduce a variable amount of dust, fan, instrumentation, and controls.

The cartridges were standard construction with 8 pleats per inch and constructed with epoxy seals and resilient gaskets. The standard rating of the collector is 2,000 cfm, which is at a filter ratio of 4.3:1 (high by industry standards, but conservative for advanced technology collectors).

Test dust was talc with a size distribution of 50% less than 8 microns.

Variables to be introduced were:

1. Air volume from 2,000 cfm to 2,600 cfm.
2. Dust concentration from .5 to 5 grains per scf.
3. Pulse duration from 50 to 75 milliseconds.
4. Pulse intervals of 15 sec., 30 sec., and 60 sec.
5. Pulse (plus induced cleaning) air at "standard" and 1.7 times standard flow.

It must be recognized that for useful comparative information to be derived in such a test, the cartridges must be able to be returned to their "initial cake" condition and not continually degrade by blinding during the test. By use of premium cartridge construction, and the practice of brief off-line cleaning after each run with an occasional air wand cleaning, we were able to demonstrate consistent starting conditions for each run.

The results of this series of tests is most interesting and is summarized as follows:

1. Increase in cleaning air per pulse is most effective as opposed to increased cleaning air by increasing pulse frequency. At 70% increase in cleaning air per pulse, the decay in starting air volume through the filter was zero for filter ratios of 4.3 and 5.0:1, and only up to 8% for filter ratio of 5.5:1 even with dust loads up to 5 gr./scf.

With "standard" pulse cleaning air, the decay in gas volume to the filter was 10% to 25% over the whole range of filter ratios and inlet loading. With "assist" cleaning, the filter drag (pressure drop divided by filter ratio) averaged 0.76 over the whole range of

inlet conditions, which is excellent performance. Standard cleaning produced a filter drag range of 0.8 to 1.3.

2. Increases in pulse frequency actually increased decay in air volume to the collector, that is it increased filter pressure drop. So it is concluded that each pulse causes penetration of particulates which begins to blind the media, and our objective should be to pulse as little as possible but to make each pulse as effective as possible.

CARTRIDGE OPERATING SUGGESTIONS

SETTING CLEANING FREQUENCY

Setting cleaning frequency for a cartridge collector with narrow pleats is very complex. A widely used procedure is to initiate the cleaning by a pressure switch. This, in theory, promises an ideal solution to get maximum efficiency of collection with minimum cleaning energy. However, the typical scenario for a cartridge collector is:

- Initially the pressure switch is set at somewhere between 3" and 4" of water.
- At the beginning, the collector cleans itself once every 60 to 120 minutes.
- The time between actuation of the cleaning cycle is gradually reduced.
- After several weeks the pressure actuation is no longer in control and the collector cleans itself continually based on the setting of the timer. This is because the pleats have become bridged (see Figure 3).

A better way of setting the cleaning cycle with a pressure switch is as follows:

- Determine the pressure drop with the cartridges clean and rated flow in the collector.
- Set the electronic timer to clean the entire collector every four minutes.
- Set the pressure switch, 1/4" w.g. above the pressure drop measured with clean air flow.
- If the pressure goes above the pressure switch setting, set the new pressure in 1/ 4 " increments until the switch controls the cleaning.

Without a pressure switch:

- Set the timer to clean the entire collector every three minutes.
- Record the pressure drop.
- After a week of operation lengthen the duration between pulses by 10%. Continue this procedure until the pressure drop rises. When it

does rise, increase cleaning frequency to the previous level, If it does not rise, leave timer at its present cleaning frequency.

CARTRIDGE RATING

The collector should be selected at a rated flow which is between 15% and 30% of the flow in the reverse jet. De-rating dust collectors is normally an effort to remedy a poor design. For example, if we put a collector with thirty cartridges on a process, which is the proper rating, and get three months cartridge life, it is likely that if we double the collector size we may get six months cartridge life. However, there will be an average ten cartridges per month which require changes in either case. By purchasing the larger collector, the user has doubled his investment and has taken up valuable floor space. A better approach might be to supply a better cartridge and cleaning system.

CARTRIDGE FAILURE MODES

BRIDGING OF PLEATS

In a cartridge collector the pressure drop across an effective cake can vary from 0.15" to 3.5" water gauge.

- If the pressure switch actuated system is used, the determination of the pressure drop setting is impossible to predict.
- The ideal design is to clean the cartridge when minimum bridging occurs. It is inevitable that some bridging will occur. The approach is to create a maximum cleanable media with a maximum of porosity (Figure 3). If any bridging occurs, loss of cleanable media will result. The cleaning air looks for the path of least resistance, which is generally where the thinnest, most porous cake is present. If the pressure switch initiation is set higher than the correct setting, the pleats can be as much as 90% bridged before the cleaning is actuated. The cake below the bridge may be very porous, but as time goes on it becomes more dense and eventually gas flow will transfer to the remaining media/cake. The remaining media with its associated cake may be inadequate to handle the load at the cleaning frequency so the pressure drop will continue to rise and the cartridge will be blinded.

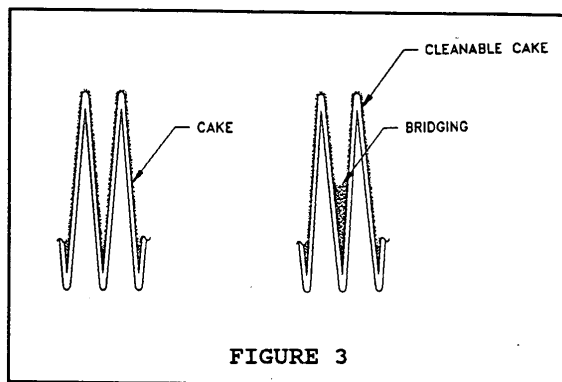

FIGURE 3

Often, cartridge collectors, especially those with cellulose media, are specified by air to cloth ratios. This is a flawed specification criterion.

Under no circumstances should the pleats be closer together than 10 pleats/inch based on the inside diameter of the cartridge. Putting pleats closer will result in excessive bridging, high pressure drop, and premature cartridge failure.

OTHER FAILURE MODES

The most serious design deficiency in any reverse jet collector is the lack of prevention of dust penetration from the clean side to the dirty side. The inherent nature of the pleated media is such that dust is not driven into adjoining filter elements during cleaning. This leaves effective permanent joint seals and gasket joint design as important elements of cartridge design (Figure 4).

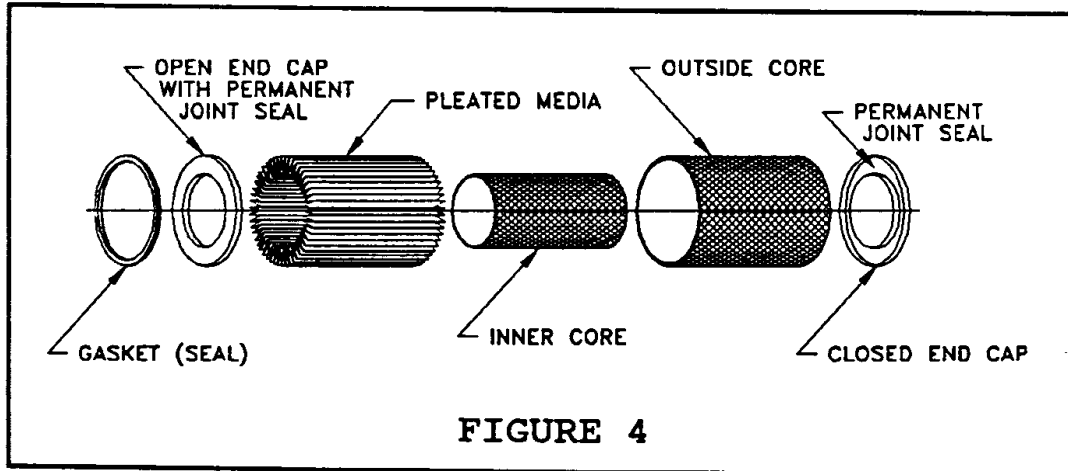

Permanent Joint Seals are defined as joints where the dust or gas barrier is permanent and is produced by an inflexible barrier that is formed on mating surfaces and held by either pressure or adhesion of the sealant material. The cartridge is constructed by submerging pleats into an adhesive/potting mixture. There are two requirements for this mixture. It must wet the media surfaces to form a dust tight joint and have sufficient strength to withstand the stress reversals put on the joint by the cleaning jets. During cleaning, 25 to 60 pounds of force are exerted by the jet on the bottom (closed) end cap. Many times thermosetting plastisols are applied. After a cartridge has failed because of dust penetration, the cartridge can be placed on a hot plate to loosen the media and the joint examined. If the joint was not strong enough, paths of dust from the dirty to the clean side can be detected along the closed end plate.

Gasketed Joints are defined as joints where the dust proof seal is due to the gasket providing pressure on the joint. These are formed by applying resilient seals to one or both of the surfaces. For cartridge collectors one of the surfaces is resilient and the other is cemented to the cartridge. Many seals lose their resiliency. If the resiliency is lost, dust will leak through the joint. When a cartridge is removed from a collector the seal should return to its original thickness within three or four minutes after its removal. If it does not, it is almost certain that dust has leaked into the inside of the cartridge and has either caused or contributed the cartridge failure. One of the most effective sealing techniques is accomplished by a retained seal with the dimensions selected so that the precise sealing pressure is maintained. If gaskets are over-stressed they

will become hard at the sealing surface and will leak enough to cause early failure of the filter element.

RECOVERY EQUIPMENT FOR BRIDGED CARTRIDGE ELEMENTS

Cartridges can often be recovered after they have failed. This is true for both cellulose and fabric pleated filter elements. Let us look at the two modes of failure that were previously discussed.

1. Failure due to bridging (without any dust penetration to the clean side):

- The first attempt should be to clean the collector off-line. This may pose a hazard because the dust may migrate down the inlet ductwork and come out of the hoods. This is especially likely if the dust collector is close coupled and the duct runs are short. The best procedure is to apply a very small flow of gas through the collector during this cleaning, typically 10% or 15% of rated flow. For some dust formulations this will bring the pressure drop to acceptable levels. This off-line cleaning should be accomplished for about twenty to fifty cycles of cleaning. When the collector is put back on-line there will be some leakage until the filter cake reestablishes itself. Remove any after filters or safety filters until the cake reforms. Usually this off-line cleaning will not be sufficient to recover the cartridges.
- The next approach should be to clean the collectors from the inside by blowing with a modified blow gun (Figure 5). The blow gun has its own internal regulator that prevents the velocity from reaching levels that would pose danger to fellow workers. The same regulator will prevent the air from leaving the tube at velocities high enough to damage even cellulose media or drive dust through an adjoining pleat if the gun is not directed radially into the pleat. This will return the cartridge to nearly new (without a porous filter cake) condition.

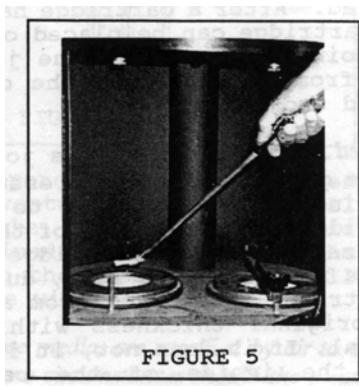

FIGURE 5

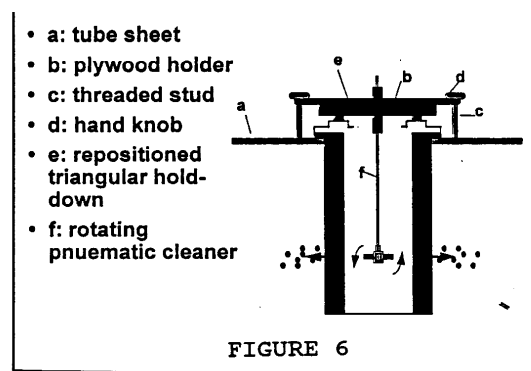

FIGURE 6

- Figure 6 illustrates a semi-automatic mechanism to accomplish this. The mechanism has a rotating jet like a lawn sprayer that whirls and give thorough coverage while it is manually raised up and down in the cartridge. Restoring cartridges with this method is most convenient with designs which allow the cartridges to be cleaned in place from the clean air side. Another method is to build a box-like fixture that is vented into another collector to allow the cartridges to be cleaned outside of the collector.

2. Failure due to dust leakage:

It is also possible to launder cartridges where dust has penetrated to the clean air side. This is very easily accomplished if the dust is soluble. The cartridges are immersed in hot water and washed with soapy water in a whirlpool type device. Next, they are rinsed and put out to dry. The seals need to be replaced unless they have recovered to their original dimensions. If the dust is insoluble, the procedure is more complex. First the outside of the pleats must be cleaned and then the inside in a separate operation. If the dust driven into the inside of the media is not removed by the washing process, the filter life of the laundered cartridge will be severely limited. If there are dust tracks below the adhesive, the life will be further reduced.

SUMMARY

Cartridge collectors have some very pronounced advantages and some unique operational features. By understanding these features, the specifier and operator can expect more efficient filtration, long cartridge element life, as well as operating at lower pressure drops with a minimum of air consumption. When designing new dust collection systems, advanced technology high-ratio designs should be specified.