

Demand Better From Your Cartridge Dust Collector

By
Gary Berwick, P.Eng.
Quality Air Management Corp.
Published November, 2006

Early Development

The cartridge dust collector was a response to the flawed design of the fabric pulse jet collector being offered on the market. In the electrostatic spray powder booths often the pigment would quickly blind many fabric pulse jet collectors. It was especially noticeable with very dense pigments. As the industry developed there was increased demand for the high density pigments. Developers of the pleated cartridge dust collectors offered the collectors and they worked well and quick blinding of the filter elements was ended. The cartridge element life was approximately four to eight months but this was acceptable for the industry in that element change was not difficult. In the first year after its introduction the cartridge collector market grew to over a million dollars. With the performance realized on the powder spray, acceptance in many industries followed quickly. The filter elements were a popular size employed as intake filters on tractor-trailer engines. The initial specifications were as follows:

Outer diameter 13.37 inches
Inner Diameter: 8.25 inches
Length: 26 inches
Number of pleats: 265
Filter media area: 185 sq. ft
Pleats per inch: 10
Media: safety media of cellulose
Inner core: usually expanded metal

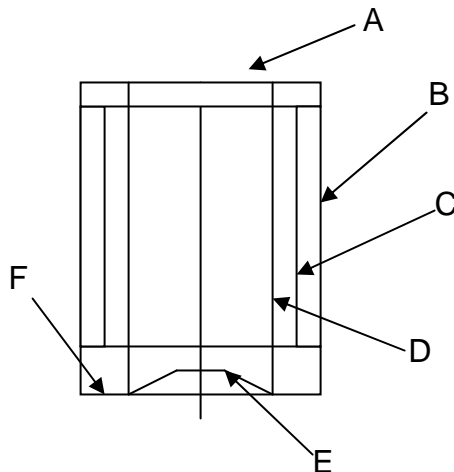

Referring to the figure above:

- A. is the open end cap generally is spun and has a thin coating of zinc to allow the spinning to be smooth during the spinning process. It also has a gasket to prevent dust leakage. ****
- B. is the outer core of expanded metal rolled and spot welded so there are no burrs at the joint *
- C. is the media enclosed between the inner and outer cores
- D. is the inner core, this is generally an expanded metal cylinder
- E. is the closed end cap. The cone built into the end cap spinning was to make room for the wing nut and spring washer with integral gasket.**
- F. is the adhesive to bind the media and cores to the end caps.***

Notes:

1. The outer core on the original collectors had a spiral bead of hot melt adhesive that connected the outer core to the media. This was to keep the pleats from flexing because of the high frequency vibration from truck engines.
2. The lower or closed end cap had a threaded rod that came through the opening in the center of the end cap. The first collectors needed clearance for installing the cartridges from inside (dirty side) of the housing.
3. The gasket was a compressible gasket which was sufficient for replaceable filters for trucks but the forces developed during the pulse cleaning process gave the gaskets a permanent set which shortened the filter element life dramatically.

4. The original adhesive was a thermosetting plastisol encapsulating compound. These compounds had poor adhesive strength. Many times the cleaning forces would break the bond between the lower end cap and the media. The dust would leak from the dirty to the clean air side, along the joint causing premature failures. Once dust enters the clean airside, subsequent cleaning pulses often drive the dust from the inside, causing an increase in resistance until the filter element requires early replacement. At least one supplier supplied adjustable springs to keep this joint under compression at all times. This increased cartridge life significantly.

The original design had the following parameters to its cleaning system components.

Pulse pipe hole size:	7/16 inch
Evasé venturi minimum diameter	3.75 inches
Reverse Air Volume	1125 CFM
Maximum Filter rating	375 CFM
Air to cloth ratio	2 FPM

This was an excellent design with the exceptions described below.

Cartridge Collector Engineering Disaster

They reached several erroneous conclusions that have dogged the industry for over 25 years:

1. That cartridge collectors can only operate at filter ratios of 2:1 or 2 fpm
2. The assumption was that they could increase the capacity of this cartridge collector by squeezing more pleats in the cartridge. As a matter of fact they put 275 sq ft of media and tried to operate at $275/185 = 557$ CFM per cartridge.

The flaw in this reasoning is there are two factors which determine the filtering capacity of a pulse jet collector. The square foot of the media that are cleanable and the volume and pressure characteristics developed by the cleaning jet. It can only clean continuously on line when the volume is at least three times the filtering volume for each cartridge and the pressure developed by the jet is at least three times the operating pressure drop. The offline cleaning characteristics are not considered in this chapter. This applies to all pulse jet collectors regardless of the shape of the filter elements.

Other limitations of early designs

A brief review of the mechanics of cleaning in a pulse jet collector is indicated.

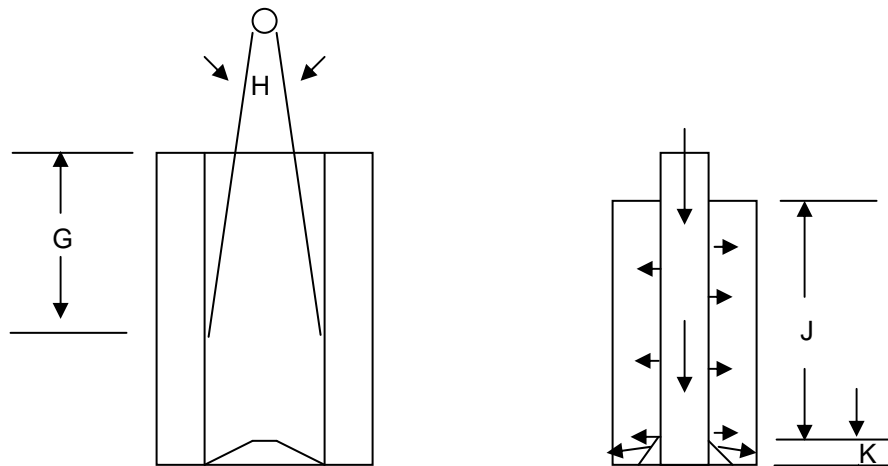

Referring to the above figures. On the left side we see that the jet grows at an angle between 14 and 16 degrees by drawing air from next to the jet. It continues this growth until it is stopped by a solid tube, an orifice or media with a filter cake. As it enters the cavity inside a filter element it forms a compression wave that stays cylindrical in the case of a round opening or any other shape built into the open end of the filter element. It continues this presumably cylindrical shape until it strikes the bottom. If the bottom of the element is flat or concave the cylinder will expand until it reaches the media from the top entrance to the bottom. The action

cleans the element evenly. However in many early designs the element had a truncated cone built into the closed end cap. When the jet struck the cone, it put an additional vector of velocity that produced a higher cleaning velocity at the bottom of the media. On many dusts this would partially damage the cake and it might take some seconds after each pulse to re-establish the cake. In the process some dust would leak into the clean air side and be driven into the media by subsequent pulses. Fortunately, this leakage was very low but the collector would have a gradually rising pressure drop which led to premature filter element replacement.

On the left side of the figure you note that if the pulse pipe was too low, the jet would strike the media below the opening in the filter element. The cleaning action above this intersection had limited effectiveness. When examining any cartridges especially tandem designs a ring of dust on the exterior of the cartridge is visible. While most cartridge collectors had much more media than required, because of this incorrect height, the added media contributed little to the filter's performance, but did raise the cost of constructing and operating the filters.

Effect of excess filter media and pressure actuated pulse controls.

In previous chapters we have discussed bridging in cartridge collectors and we will not repeat the discussion at this point, except to remind that once a bridge forms in the valley of the pleat, it renders the media below the bridge un-cleanable by on line cleaning.

If a cleaning system is actuated by a pressure control, the setting must be determined by experimentation since it is virtually impossible to predict the best pressure setting before the collector is installed. If it is set at a higher pressure this will affect operating pressure, frequency of cleaning (air consumption) and dust penetration through the filter. Typically a collector pressure switch is set at 3 ½ w.c. when the proper setting might be 2 " w.c. Below are typical operating parameters at the correct and incorrect settings for a typical operation venting a material handling operation:

Operating at Correct setting for 4,000 CFM system with 3 grains per cubic foot load:

Pressure Drop	2 inch w.c
Air Consumption at 85 psig	1.5 SCFM
Dust Penetration	4x10 ⁻⁵ grains/cu ft.
Cartridge life	18 months

Operating at Incorrect setting for 4,000 CFM system with 3 grains per cu. ft. load:

Pressure drop	3.5 inch water column
Air consumption at 85psig	4.5 SCFM
Dust Penetration	12x10 ⁻⁵ grains/cu.ft.
Cartridge life	6 months.

Notice that operating power is 1.32 higher, air consumption and dust emissions are increased 3 times, cartridge life is only 1/3.

Improvements in Cartridge Filter Design

Adhesives

The encapsulating compounds were replaced by adhesives. Epoxies and various thermo-setting adhesives were supplied. This resulted in a stronger stiffer cartridge. Cartridges were able to be constructed without the expanded outer core. To keep the pleats from inverting during the cleaning process, plastic bands or even strings were applied with great success. These stronger and more open cartridges opened up new applications for cartridge collectors.

Media Changes

To go along with the changes in adhesives stronger cellulose media was developed. They were reinforced with polyester and other fibers. This increased the tensile strength by three or four times and allowed the introduction of more powerful cleaning systems to increase flow per filter element. Another important development was incorporation of pleat spacers, by upsetting the tips of the pleats. This solved a problem in constructing cartridges by eliminating wide variations in pleat spacing. A section of pleats that were too narrow would bridge too easily.

Seals

In the quest to prevent any leakage from the dirty to the clean side of the cartridge, resilient seals were added. The new seals could maintain an even pressure on the sealing surfaces. In order to maintain a good seal the pressure must remain within a narrow range of pressure. They can be tightened so much that sealing compounds will go beyond their plastic limit and produce uneven pressure and actually leak through the joint. The natural tendency for many maintenance people is to over tighten gaskets and seals. Some gaskets are designed to be squeezed beyond their elastic limit and flow along the joint. This is similar to the gaskets applied in gasoline engines. However the valve cover gasket is really an elastic seal. In cartridge mounting systems, the gaskets would need so much pressure that the cartridge would be damaged. For this reason elastic seals must be applied. Stops are often built into the seals themselves. Refer to the diagram below:

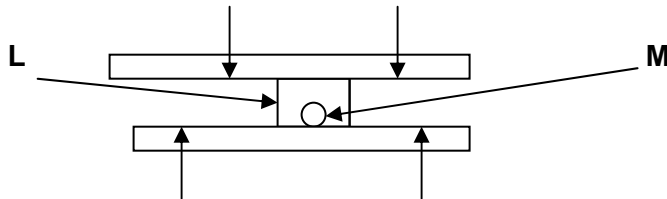

A resilient seal, labeled L is placed between the sealing service presumably round, and at 120 degree intervals the seal is slit and a ball bearing, labeled M, is dropped into the slot. This maintains sufficient sealing pressure but does not allow over compression of the seal. Other stops can be incorporated into the mounting system.

Un-cleaned media considerations

The area of filter media that can be cleaned depends on the reverse air volume and pressure of the reverse air jet. If we consider different orifices and valves and assuming a permeability of 18 -20 CFM at 0.5 inches of pressure drop for a sq. ft of the base media, the area of media cleaned is:

¼ "orifice	7 - 10 sq. ft.
3/8 "orifice	15 - 20 sq. ft.
7/16" orifice	22 - 26 sq. ft.
½ inch orifice	28 - 37 sq. ft.
¾ inch valve	75 - 78 sq. ft (Most common in use)
1 inch valve	210 - 220 sq. ft.

If we consider a typical tandem design with two cartridges, each being cleaned by a single ¾ inch valve. Only about 80 square feet of media are cleaned. We find that the media can hold 0.1 to 0.3 lbs of mineral dust if it is not cleaned.

We can compute the weight of dust on the un-cleaned media.

450 sq. ft. total less 80 sq ft. cleaned by pulse jet = 370 sq. ft.

370 sq. ft. x (0.1 to 0.3 lb.) per sq. ft. = 37 to 110 lb per 2 cartridge tandem cleaning sets.

On some of the later designs the mounting bolts on the cartridge support tripods had to be reinforced to prevent mounting failures.

Cartridge Construction Improvements

Some other innovations to improve cartridge construction were the following.

- Many new designs included a flat bottom on the closed end cap.
- Some designs incorporated a flat disc above the truncated cone
- Spun bond and other medias were introduced to counter the tendency of cellulose medias to expand and shrink with changes in humidity. Other cartridges were supplied with pleated medias even woven or felted media and were quite successful. With these new constructions pleated elements with wide pleat spacing operated at filter ratios of over 10.

Flexible Media pleated filter elements

One limitation of some spun bond and felted medias was that they would have poor operation if the pleats were too narrow or lacked mechanical support of the media itself.

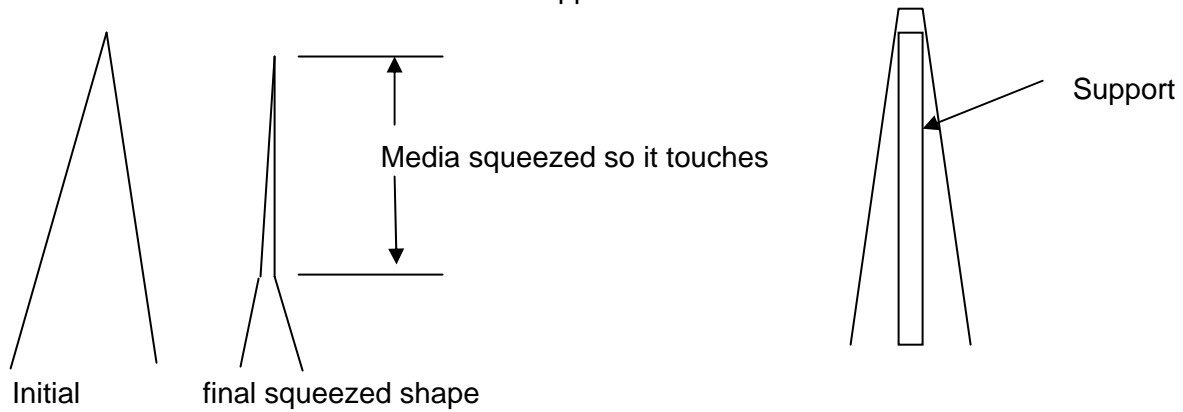

The support can be a laminate that is stiff but a very open media. This allows the use of virtually any media in pleated construction.

Conclusion

The users and designers of dust collectors have the possibility of virtually unlimited filter element life at negligible dust penetration. If the seals are intact and no dust penetration occurs to the clean side, cartridge filters can be restored to 'as new' condition.