



Compact LC Series Baghouse Dust Collector

GREEN! Environmentally Friendly Features

- ❖ **Unmatched filtration efficiency** by totally eliminating filter leakage and dust penetration (often referred to as “puffing”) during cleaning cycles.
- ❖ **40% lower power consumption** & operating pressure drop.
- ❖ Half the number of bag filters to the landfill. 3-4 times longer filter life means even **less disposal of filters required**.
- ❖ Reduced cleaning frequency, less compressed air consumption by up to 65%.
- ❖ The **only baghouse technology** that **allows air recirculation to the work area** without after filters. Save on heating and cooling energy consumption.

World’s Most Advanced Pulse-Jet Technology

- Field proven for over 25 years.
- Suitable for **all types of granular dusts**.
- Resists the effects of abrasive dusts.
- Optional feeder system to blot out oily dusts, such as welding fumes.
- Optional special precautions, such as pulse cleaning of baffle for irregular dusts like paper strips, woodworking etc.

Lower Purchase Price

- Smaller, lighter dust collector.
- No frills design. Simpler cleaning components.
- Smaller blower and motor required.

50–80% Lower Operating Cost

- Hi-Tech cleaning system **extends bag filter life by 3-4 times** over that of conventional baghouse dust collectors.
- **Half the filter elements to service; save money and labor.**

Smaller and Lighter Dust Collector

- 35% less floor space.
- Less height to fit in most buildings.
- 40% less weight, lower cost LTL shipping.
- Can be floor mounted, indoor or outdoor.

Manufacturing and Suppliers are exclusively USA and Canadian



LC30H (internal view through the access door)
With optional
Portable trash bin

2400 CFM Dust Collector	LC Series Collector	Contemporary Bag Collector
Purchase Price	\$7600	\$8500 - \$9100
Dust Emissions	<i>only</i> 10 x 10⁻⁵ grains/cu.ft.	800 x 10⁻⁵ grains/cu.ft.
Foot Print	<i>only</i> 27 x 39 inches	55 x 56 inches
Height	<i>only</i> 76 inches (LP version)	127 inches
Weight	<i>only</i> 1150 lbs	1900 lbs
Blower / Motor	<i>only</i> 2.19 BHP	3.5 BHP
Number of Bags	<i>only</i> 18	36
Filter Life	3-6 years	1-3 years
Air Consumption	<i>only</i> 1.74 SCFM	9.42 SCFM

Technical Features

Referring to the drawing on the right;

1. Most Advanced Pulse Jet Cleaning Technology

- ✓ Pulse jet designed to produce compression wave over the entire filter media surface, therefore cleaning 90+% of the bag filter. Conventional designs clean 20-25% at most.
- ✓ A high volume – low velocity pulse jet maintains the ultimate stable dust cake, producing unmatched filtration efficiency on dry particulate. Conventional designs use low volume – high velocity jets which cause much dust penetration to the clean side and are dependent on filter (air-to-cloth) -ratio selection.
- ✓ **95-99% filtration efficiencies are achieved.** The stable filter cake causes air and dust loading to be uniform over the entire filter area.
- ✓ Runs at 1/3 of the pressure drop and cleaning frequency, compared to conventional dust collectors.
- ✓ Only 1/3 of the bags are pulsed at once, preventing blowback in the system.
- ✓ Pulse pipes and diaphragm valves are computer selected for each application and sized for 125% of the required flow.
- ✓ Optional supersonic nozzles produce 3.6 times more cleaning power, reducing compressed air consumption a further 35%.

2. Positive Seal System

- ✓ Prevents any possibility of leakage from the dirty air side to the clean air side. This is the most common failure mode for bag style dust collectors.

3. Easy to Service Bottom Load Bags and Cages.

4. High Side Inlet, leading to a Large Distribution Chamber

- ✓ Large, high, side inlet slows down the dust particles allowing most of the heavy and impulsive dust loads to be absorbed and dropped directly to the hopper or dust tray. This greatly reduces the dust loading on the filter bags.
- ✓ Prevents upward “can velocity” by ensuring a net down flow towards the dust tray or hopper. With conventional dust collectors, light and fluffy dust hangs up in the filter bags due to upward flow from a low hopper inlet.

5. Large Access Door

- ✓ Easy servicing and bag filter replacement.

6. Optional Perforated Baffle

- ✓ Computer designed to optimize distribution of air across the bag filter compartment.
- ✓ Reduces abrasion of the bag filters.

Models Available

- 500, 720, 960, 1440, 2400, and 4800 CFM
- Low-profile dust tray configurations.
- Hopper and legs configurations which can be used with a 5 gallon pail or 55 US gallon drum.
- Top-mount blowers, matched to the collector for optimal performance.

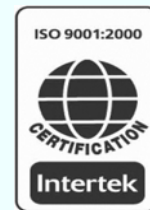
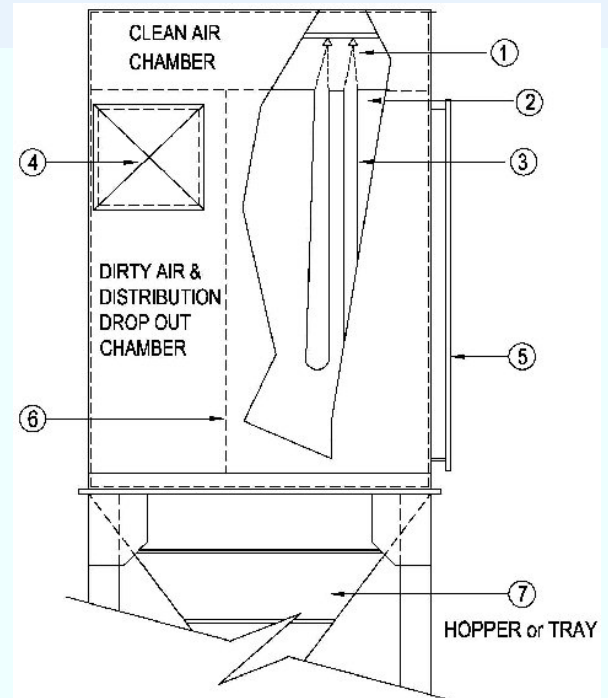

Quality Air Management reserves the right to change design and specifications without notice

Sold and Serviced by:



Quality Air Management

www.gamanage.com

T: 1-800-267-5585