

ULTRA-FLOW

Cartridge Dust Collector

Universal Application Self-Cleaning Dust Collector

- **The only** pulse jet self-cleaning cartridge dust collector that can handle heavier dust loads which are normally reserved for inefficient baghouse collectors.
- **HEPA type efficiency** on dry particulate when filter cake is built.
- **Superior vertically mounted cartridge filters** ensures dust falls to hopper.
- Suitable for all types of granular dusts.
- Whisper quiet cleaning system.
- Resists the effects of abrasive dusts.
- Optional feeder system to blot out oily dusts, such as welding fumes.
- Optional special precautions, such as pulse cleaning of baffle for irregular dusts like paper strips, woodworking etc.

Lower Purchase Price

- Smaller, lighter dust collector.
- Half the number of cartridge filter elements.
- Simpler design of cleaning components.
- Smaller blower and motor required.

Lower Operating Cost

- Advanced Hi-Tech cleaning system extends filter life by 3 to 5 times that of conventional dust collectors.
- Half the filter elements to service; save money and labor.
- 40-50% Lower power consumption by reducing operating pressure drop.
- Reduced cleaning frequency and accelerating nozzles reduce compressed air consumption by a further 35%.

Smaller and Lighter Dust Collector

- Compact design.
- 35-50% less floor space.
- Up to 50% less height to fit in most buildings.
- 35-50% less weight, low cost LTL shipping.
- Can be floor mounted or ceiling hung.



CV412 on welding fumes



4200 CFM Collector	UltraKlean™ Dust Collector	Contemporary Cartridge Collector
Applied To	Any granular dust	Light dust loads only
Purchase Price	\$9,000 - \$11,000	\$14,000 – \$19,000
Dust Emissions	1.5 x 10⁻⁵ grains/cu.ft.	3.0 x 10⁻⁵ grains/cu.ft.
Foot Print	57 x 44 inches	84 x 48 inches
Height	141 inches	154 inches
Weight	1275 lbs	2180 lbs
Blower / Motor	7.5 HP	10 HP
Filter Cartridges	6	12
Filter Life	6 - 36 months	3 - 12 months

FEATURES

Referring to the drawing on the right;

1 Top Access

- Easy servicing and cartridge filter replacement, outside of the dirty air chamber.

2 Most Advanced Pulse Jet Cleaning Technology

- Pulse jet designed to produce compression wave over the entire filter media surface, therefore cleaning 90+% of the cartridge element.
- Maintains ultimate dust cake, producing **HEPA type efficiencies** on dry particulate.
- Reduces cleaning frequency and pressure drop by more than 50%.
- Only 1/3 of cartridges are pulsed at once, preventing blowback in system.
- Pulse pipes and diaphragm valves are computer selected for each application and sized for 125% of the required flow.
- Optional supersonic nozzles produce 3.6 times more cleaning power, reducing power consumption a further 35%.

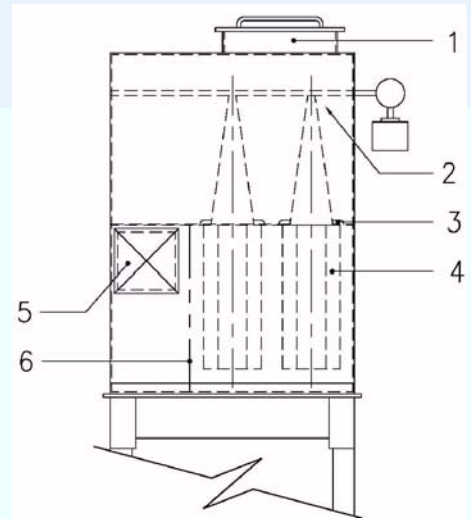

3 Positive Seal System

- Prevents any possibility of leakage from the dirty air side to the clean air side. This is the most common failure mode for cartridge collectors.
- As the cartridge loads and gains some weight, the sealing actually improves. With the common horizontal cartridge configuration (especially tandem units), the dust weight causes the gasket seals to detach and develop significant leaks, another common failure mode.

4 FLO-MAX™ Cartridge Filter Elements

- Hi-tech design allows high-ratio operation and using half the number of filters.
- **Truly washable** proprietary media cartridge filters. Conventional polyester softens and pinches after washing. Cellulose (paper) and 80/20 paper filters break down, contracting the pores of the media, and choking air flow.
- **Very low operating pressure drop** of 1.5 to 2.5 inches WC; Computer selected orifice plates and evasé enhance the cleaning efficiency.
- **Vertical mounting** prevents pleat bridging of 1/3 of the cartridge as is the case with horizontal mounting. Dust falls directly into the hopper or dust tray, and not on the cartridges below.
- **Bridging and clogging is prevented** by extra wide pleat spacing stops dust from bridging across the pleats, even with heavier dust loads.
- **Pleat pinching is prevented**; a proprietary design using extra stiff filter media, dimpled and a tandem pleat backing. This is another most common cartridge failure mode. Pinching can reduce the working area of media to as low as 10% and has no way of recovering.

5 Side Inlet, Leading to Large Distribution Chamber

- Large, high, side inlet slows down the dust particles allowing most of the heavy and impulsive dust loads to be absorbed and dropped immediately to the hopper or dust tray. This greatly reduces the dust loading on the filter cartridges.

6 Optional Perforated Baffle

- Computer designed to optimize distribution of air across the cartridge filter elements and prevent excessive upward "can velocity".
- Reduces abrasion of the cartridges.

Models Available

- 450 and 900 CFM low height compact units.
- 1000 and 2000 CFM medium height units.
- 4200, 8400 and 12,600 CFM larger units.
- Modular design allows for building any multiple of the sizes mentioned above.
- Standard hopper or low-profile dust tray configurations.

Quality Air Management reserves the right to change design and specifications without notice.

Sold and Serviced by:



www.qamanage.com

T: 1-800-267-5585