

Auto Booster - Duct Cleaner



BOOSTER in 64" duct



BOOSTER cleans QUENCHER spark arrestor

- Clean Dust Drop-out In Ductwork
 - Unplug blockages in pneumatic conveying
 - Easy solution to boost low flow conditions in ducts
 - Reduce Fires and Explosions hazard in ducts
 - Clean out dust accumulations in spark arrestors and other devices in airstreams
-
- ❖ Simple duct cleaning mechanism
 - ❖ Simply insert in the duct section
 - ❖ Uses advanced pulse jet technology
 - ❖ Each pulse boosts air flow by 2-4 times
 - ❖ Cleans up to 100 feet of duct
 - ❖ Available in all duct sizes

Booster - Duct Cleaner

1. header accumulator
2. solenoid diaphragm valve
3. duct mounting plate
4. Self tapping screws
5. duct section
6. (optional) supersonic nozzles

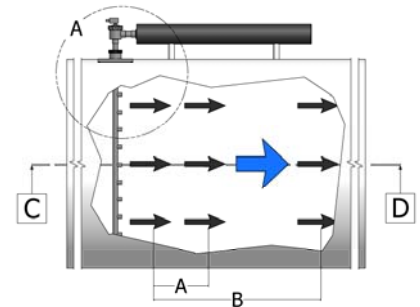
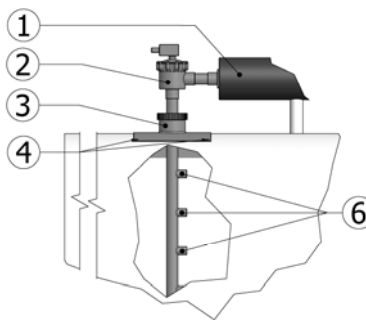

The duct booster is a pneumatically propelled jet generating system using the same jet pump design and components as are found in advanced technology pulse jet dust collectors. It is like having a booster fan in the duct system, with no moving parts. It will increase air speed in ducts by 3000-5000 feet per minute for short bursts of time. This will pick up the dust lying on the bottom of the duct and push it along to the dust collector. The air jets also remove electrostatic charges on the duct surfaces which are a source of ignition. When averaged over a day's operation the cleaner need not be actuated except once in every one to four hours, and therefore air consumption is negligible. The Booster is usually powered by shop air at 85 PSI. Optional supersonic nozzles can be added to the blow pipes for more efficient pressure-to-velocity conversion.

It can also be designed for various low air pressures from 7-20 PSI, thereby allowing operation where shop air is not readily available.

The duct cleaner can be actuated by a manual push button or using the output from one of the positions on a pulse sequencer controlling the cleaning cycle of a dust collector.

Sold and Serviced by:



Manufactured by QAM
 Waterloo, Ontario, Canada
 Web-site: www.qamanage.com
 Phone: (800) 267-5585
 Fax: (866) 899-8954